

iC-PT 3325

6-CH. PHASED ARRAY OPTO ENCODER (33-2500)



Rev C1, Page 1/11

FEATURES

- ◆ Monolithic photodiode array with excellent signal matching
- ◆ Very compact size for small encoders
- ◆ Moderate track pitch for relaxed assembly tolerances
- ◆ Low noise signal amplifiers with high EMI tolerance
- ◆ Single-pin programming of 3 operating modes: analog, digital (2500 CPR), and x2 interpolated (5000 CPR)
- ◆ Analog signals for alignment and resolution enhancement
- ◆ Available with ungated or B-gated index signal (1 T or 0.5 T)
- ◆ Complementary outputs: A, B, Z and NA, NB, NZ
- ◆ Up to 20,000 RPM at 2500 CPR (10,000 RPM at 5000 CPR)
- ◆ U, V, W commutation signals, analog and digital
- ◆ All outputs +/- 4 mA push-pull, current-limited and short-circuit-proof
- ◆ LED power control with 40 mA high-side driver
- ◆ Single 3.5 V to 5.5 V operation, low power consumption
- ◆ Operating temperature range of -40 °C to +110 °C (+120 °C)
- ◆ Code disc available: PT5S 33-2500 (glass 1 mm)
OD \varnothing 33.2 mm, ID \varnothing 13.0 mm, optical radius 14.5 mm,
2500 ppr and 4 ppr commutation (90°)

APPLICATIONS

- ◆ Incremental encoder
- ◆ Brushless DC motor commutation
- ◆ Industrial drives

PACKAGES

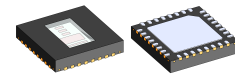

32-pin optoQFN
5 mm x 5 mm x 0.9 mm
RoHS compliant

BLOCK DIAGRAM

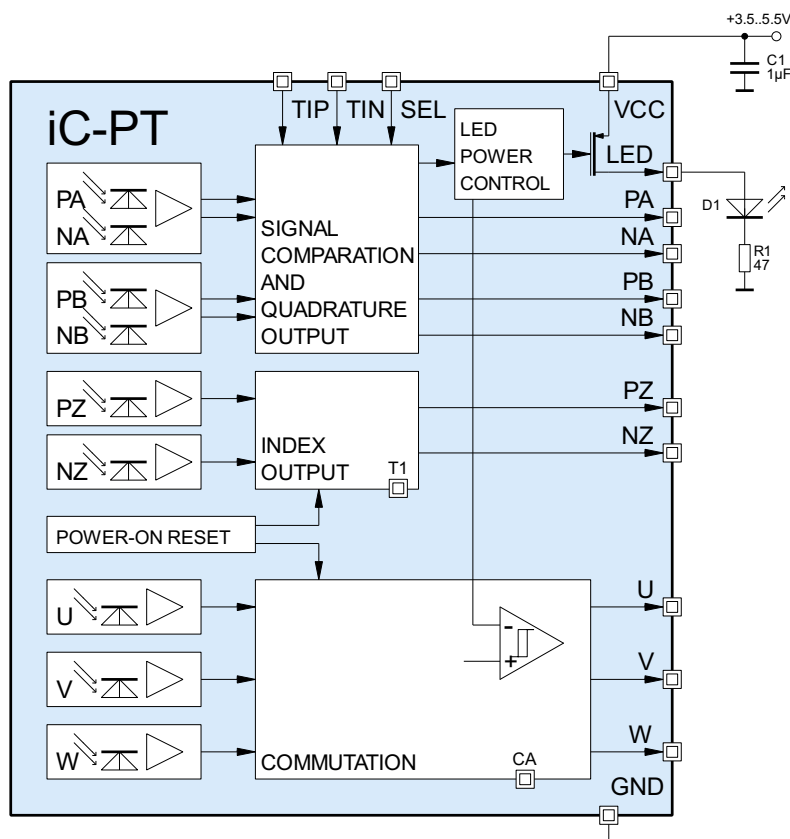

iC-PT 3325

6-CH. PHASED ARRAY OPTO ENCODER (33-2500)



Rev C1, Page 2/11

DESCRIPTION

iC-PT 3325 is an optical sensor IC with integrated photosensors whose signals are converted into voltages by low-noise transimpedance amplifiers. Precise voltage comparators with hysteresis are used to generate the digital signals, supplied to the output pins via differential +/- 4 mA push-pull drivers.

The built-in LED power control with its 40 mA driver stage permits a direct connection of the encoder LED. Regardless of aging or changes in temperature the received optical power is kept constant.

Selection input SEL chooses for three different operating modes: regular A/B operation, A/B operation with 2-fold interpolation, or analog operation. With analog operation the amplified signal voltages are available at the outputs for inspection and monitoring encoder assembly.

Typical applications of iC-PT devices are incremental encoders for motor feedback and commutation. To this end, device version iC-PT 3325 provides differential A/B tracks and a differential index track, each consisting of multiple photo sensors. The layout of the signal amplifiers is such that there is an excellent paired channel matching, eliminating the needs for signal calibration.

Additionally, three more tracks are provided to generate motor commutation information for the U, V and W outputs, for instance with 90 degree phase shift to operate 4-phase brushless motors. The period count and phase shift can be varied by the code disc applied.

PACKAGING INFORMATION

PAD LAYOUT

Chip size 2.88 mm x 3.37 mm

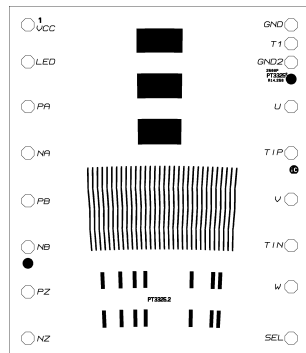

PAD FUNCTIONS

No. Name Function

See pin configuration.

SENSOR LAYOUT

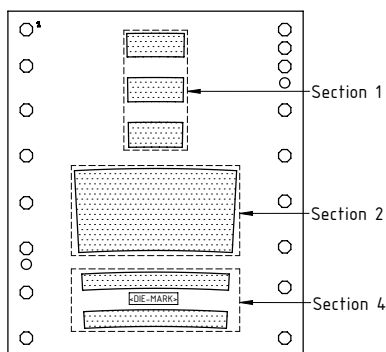

dra_ptxxx_optoKinfo

AOI CRITERIA

<Die Mark>	<Section>	<Area Class> ¹
iC PT3325.2	1, 4	A40
	2	A25

¹ Selection class for the optical inspection of detector areas. Refer to [Optical Selection Criteria](#) for further description.

iC-PT 3325

6-CH. PHASED ARRAY OPTO ENCODER (33-2500)



Rev C1, Page 3/11

PIN CONFIGURATION

oQFN32-5x5-1, oQFN32-5x5-2 (5 mm x 5 mm)

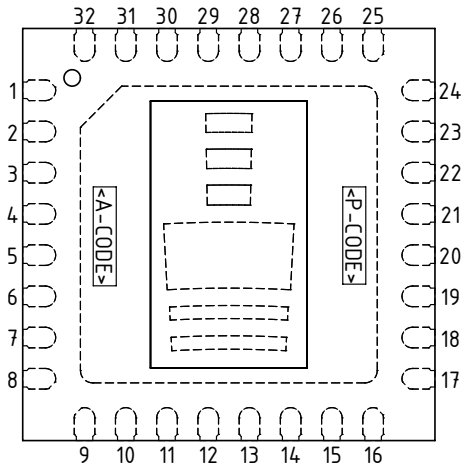

PIN FUNCTIONS

No.	Name	Function
1	VCC	+3.5 V...+5.5 V Supply Voltage
2	LED	LED Controller, High-Side Current Source Output
3	PA	Push-Pull Output A+ / Analog Sin+ ¹
4	NA	Push-Pull Output A- / Analog Sin-
5	PB	Push-Pull Output B+ / Analog Cos+
6	NB	Push-Pull Output B- / Analog Cos-
7	PZ	Push-Pull Output Z+ / Analog Z+
8	NZ	Push-Pull Output Z- / Analog Z-
9..16	n.c. ²	
17	SEL	Op. Mode Selection Input: lo = digital hi = x2 interpolated open = analog (alignment aid)
18	W	Push-Pull Output W / Analog W
19	TIN	Negative Test Current Input ³
20	V	Push-Pull Output V / Analog V
21	TIP	Positive Test Current Input ³
22	U	Push-Pull Output U / Analog U
23	n.c.	
24	GND	Ground
25..32	n.c.	
	BP	Backside Paddle ⁴

IC top marking: <P-CODE> = product code, <A-CODE> = assembly code (subject to changes);

¹ Capacitive pin loads must be avoided when using the analog output signals.

² Pin numbers marked n.c. are not connected.

³ The test pins TIP and TIN may remain unconnected.

⁴ Connecting the backside paddle is recommended by a single link to GND. A current flow across the paddle is not permissible.

iC-PT 3325

6-CH. PHASED ARRAY OPTO ENCODER (33-2500)



Rev C1, Page 4/11

PACKAGE DIMENSIONS

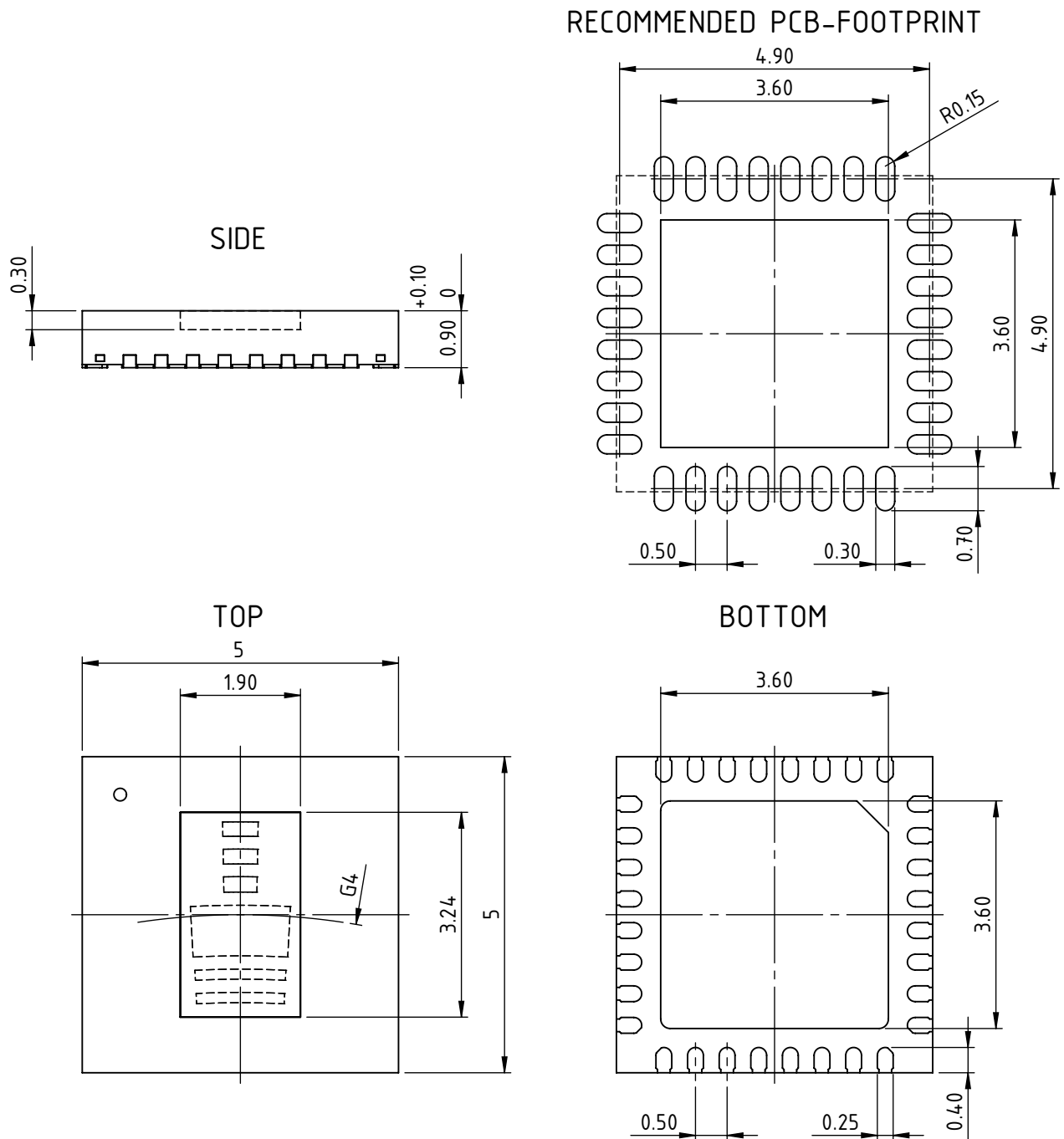

All dimensions given in mm. General Tolerances of form and position according to JEDEC MO-220.
Positional tolerance of sensor pattern: $\pm 70\mu\text{m}$ / $\pm 1^\circ$ (with respect to center of backside pad).
G4: radius of chip center (refer to the relevant encoder disc and code description).
Maximum molding excess $+20\mu\text{m}$ / $-75\mu\text{m}$ versus surface of glass. Small pits in the mold surface, which may occasionally appear due to the manufacturing process, are cosmetic in nature and do not affect reliability.

iC-PT 3325

6-CH. PHASED ARRAY OPTO ENCODER (33-2500)



Rev C1, Page 5/11

ABSOLUTE MAXIMUM RATINGS

These ratings do not imply operating conditions; functional operation is not guaranteed. Beyond these ratings device damage may occur.

Item No.	Symbol	Parameter	Conditions			Unit
				Min.	Max.	
G001	VCC	Voltage at VCC		-0.3	6	V
G002	I(VCC)	Current in VCC		-20	20	mA
G003	V()	Voltage at Output Pins PA, NA, PB, NB, PZ, NZ, U, V, W		-0.3	VCC + 0.3	V
G004	I()	Current in Output Pins PA, NA, PB, NB, PZ, NZ, U, V, W		-20	20	mA
G005	V()	Voltage at LED		-0.3	VCC + 0.3	V
G006	I()	Current in LED		-120	20	mA
G007	V()	Voltage at TIP, TIN, SEL		-0.3	VCC + 0.3	V
G008	I()	Current in TIP, TIN, SEL		-20	20	mA
G009	Vd()	ESD Susceptibility, all pins	HBM, 100 pF discharged through 1.5 kΩ		2	kV
G010	Tj	Junction Temperature		-40	150	°C
G011	Ts	Chip Storage Temperature Range		-40	150	°C

THERMAL DATA

Item No.	Symbol	Parameter	Conditions				Unit
				Min.	Typ.	Max.	
T01	Ta	Operating Ambient Temperature Range		-40		110	°C
T02	Ts	Permissible Storage Temperature Range		-40		120	°C
T03	Tpk	Soldering Peak Temperature	tpk < 20 s, convection reflow tpk < 20 s, vapor phase soldering MSL 5A (max. floor life 24 h at 30 °C and 60 % RH); Refer to Handling and Soldering Conditions for details.			245 230	°C °C

All voltages are referenced to ground unless otherwise stated.

All currents flowing into the device pins are positive; all currents flowing out of the device pins are negative.

iC-PT 3325

6-CH. PHASED ARRAY OPTO ENCODER (33-2500)



Rev C1, Page 6/11

ELECTRICAL CHARACTERISTICS

Operating conditions: VCC = 3.5...5.5 V, Tj = -40...125 °C, $\lambda_{LED} = \lambda_r = 740$ nm, unless otherwise noted

Item No.	Symbol	Parameter	Conditions				Unit
				Min.	Typ.	Max.	
Total Device							
001	VCC	Permissible Supply Voltage		3.5		5.5	V
002	I(VCC)	Supply Current in VCC	no load, photocurrents within op. range		3	10	mA
003	Vc(lo)	Clamp-Voltage lo at all pins	I() = -4 mA, versus GND	-1.2		-0.3	V
004	Vc(hi)	Clamp-Voltage hi at all pins	I() = 4 mA			11	V
005	Vc(hi)	Clamp-Voltage hi at LED, PA, NA, PB, NB, PZ, NZ, U, V, W	I() = 4 mA, versus VCC	0.3		1.2	V
006	Vc(hi)	Clamp-Voltage hi at SEL, TIP, TIN	I() = 4 mA, versus VCC	0.7		2.2	V
Photosensors							
101	λ_{ar}	Spectral Application Range	$Se(\lambda_r) = 0.25 \times S(\lambda)_{max}$	400		950	nm
102	λ_{pk}	Peak Sensitivity Wavelength			680		nm
103	Aph()	Radiant Sensitive Area	PA, PB, NA, NB (sum of segments) U, V, W (per segment) PZ, NZ (sum of segments)		0.072 0.1 0.038		mm ² mm ² mm ²
104	S(λ_r)	Spectral Sensitivity	$\lambda_{LED} = 740$ nm $\lambda_{LED} = 850$ nm		0.5 0.3		A/W A/W
106	E()mxpk	Permissible Irradiance	$\lambda_{LED} = \lambda_{pk}$, Vout() < Vout()mx; PA, PB, NA, NB U, V, W PZ, NZ		2.3 1.1 3.2		mW/ cm ² mW/ cm ² mW/ cm ²
Photocurrent Amplifiers							
201	Iph()	Permissible Photocurrent Operating Range		0		550	nA
202	$\eta()$ r	Photo Sensitivity (light-to-voltage conversion ratio)	for PA, PB, NA, NB for PZ, NZ, U, V, W	0.1 0.2	0.3 0.4	0.5 0.6	V/ μ W V/ μ W
203	Z()	Equivalent Transimpedance Gain	Z = Vout() / Iph(), Tj = 27 °C; for PA, PB, NA, NB for PZ, NZ, U, V, W	0.56 0.66	0.75 1.0	1 1.36	M Ω M Ω
204	TCz	Temperature Coefficient of Transimpedance Gain			-0.12		%/°C
205	$\Delta Z()$ pn	Transimpedance Gain Matching	SEL open, P vs. N path per diff. channel	-0.2		0.2	%
206	$\Delta V_{out}()$	Dark Signal Matching of A, B	SEL open, output vs. output	-8		8	mV
207	$\Delta V_{out}()$	Dark Signal Matching of U, V, W	SEL open, output vs. output	-12		12	mV
208	$\Delta V_{out}()$	Dark Signal Matching of A, B, Z, U, V, W	SEL open, any output vs. any output	-24		24	mV
209	$\Delta V_{out}()$ pn	Dark Signal Matching	SEL open, P vs. N path per diff. channel	-2.5		2.5	mV
211	fc(hi)	Cut-off Frequency (-3 dB)		400	500		kHz
Analog Outputs PA, NA, PB, NB, PZ, NZ, U, V, W							
301	Vout()mx	Maximum Output Voltage	illumination to E()mxpk	1.04	1.27	1.8	V
302	Vout()d	Dark Signal Level	load 100 k Ω vs. +2V	560	770	985	mV
303	Vout()acmx	Maximum Signal Level	Vout()acmx = Vout()mx - Vout()d	0.3	0.5	0.75	V
304	Isc(hi)	Short-Circuit Current hi	SEL open, load current to ground	100	1800	3000	μ A
305	Isc(lo)	Short-Circuit Current lo	SEL open, load current to IC	20	40	200	μ A
306	Ri()	Internal Output Resistance	f = 1 kHz	250	750	2250	Ω
Comparators							
401	Vt(hi)	Upper Comparator Threshold	Iph()p x Z()p > Iph()n x Z()n, resp. Iph()p x Z()p > internal VREF	5	12	25	mV
402	Vt(lo)	Lower Comparator Threshold	Iph()p x Z()p < Iph()n x Z()n, resp. Iph()p x Z()p < internal VREF	-25	-12	-5	mV
403	Vt(hys)	Comparator Hysteresis	Vt(hys) = Vt(hi) - Vt(lo)	10	24	50	mV

iC-PT 3325

6-CH. PHASED ARRAY OPTO ENCODER (33-2500)



Rev C1, Page 7/11

ELECTRICAL CHARACTERISTICS

Operating conditions: VCC = 3.5...5.5 V, Tj = -40...125 °C, $\lambda_{LED} = \lambda_r = 740$ nm, unless otherwise noted

Item No.	Symbol	Parameter	Conditions				Unit
				Min.	Typ.	Max.	
LED Power Control							
501	Iop()	Permissible LED Output Current		-40		0	mA
502	Vs()hi	Saturation Voltage hi	Vs()hi = VCC - V(LED); I() = -40 mA	0.25	0.5	1	V
503	Isc()hi	Short-Circuit Current hi	V() = 0 V	-150		-50	mA
Digital Outputs PA, NA, PB, NB, PZ, NZ, U, V, W							
601	fout	Maximum Output Frequency		800			kHz
602	Vs()lo	Saturation Voltage lo	VCC = 4.5...5.5 V, I() = 4 mA, Tj = 70 °C			0.4	V
603	Vs()lo	Saturation Voltage lo	VCC = 4.5...5.5 V, I() = 4 mA, Tj = 85 °C			0.5	V
604	Vs()lo	Saturation Voltage lo	VCC = 3.5...4.5 V, I() = 4 mA			0.6	V
605	Isc()lo	Short-Circuit Current lo	V() = VCC	7		70	mA
606	Vs()hi	Saturation Voltage hi	Vs()hi = VCC - V(), I() = -4 mA; VCC = 4.5...5.5 V VCC = 3.5...4.5 V			0.4 0.6	V V
607	Isc()hi	Short-Circuit Current hi	V() = 0 V	-70		-7	mA
Selection Input SEL							
701	Vt1()hi	Upper Threshold Voltage hi	for A/B mode with x2 interpolation	78	80	82	%VCC
702	Vt1()lo	Upper Threshold Voltage lo	for A/B mode with x2 interpolation	68	70	72	%VCC
703	Vt1()hys	Upper Threshold Hysteresis	Vt1()hys = Vt1()hi - Vt1()lo	8	10	12	%VCC
704	Vt2()hi	Lower Threshold Voltage hi	for A/B mode	28	30	32	%VCC
705	Vt2()lo	Lower Threshold Voltage lo	for A/B mode	18	20	22	%VCC
706	Vt2()hys	Lower Threshold Hysteresis	Vt2()hys = Vt2()hi - Vt2()lo	8	10	12	%VCC
707	V0()	Pin-Open Voltage	for analog mode	45	50	55	%VCC
708	Rpd()	Pull-Down Resistor	SEL to GND, V(SEL) = VCC	70	100	140	k Ω
709	Rpu()	Pull-Up Resistor	VCC to SEL, V(SEL) = 0 V	70	100	140	k Ω
710	Vpd()	Pull-Down Voltage vs. VCC/2	Vpd() = V() - VCC/2; I() = 0...5 μ A			0.5	V
711	Vpu()	Pull-Up Voltage vs. VCC/2	Vpu() = V() - VCC/2; I() = -5...0 μ A	-0.5			V
Test Circuit Inputs TIP, TIN							
801	I()test	Permissible Test Current Range	test mode active	10		600	μ A
802	V()test	Test Pin Voltage	test mode active, I() = 200 μ A	1.25	1.5	1.75	V
803	Ipd()	Test Pin Pull-Down Current	test mode not active, V() = 0.4 V	60	100	160	μ A
804	Ipd()	Test Pin Pull-Down Current	V() = VCC	0.7	2	3	mA
805	It()on	Test Mode Activation Threshold		80	130	190	μ A
806	CR()	Test Mode Current Ratio I()/Iph()	test mode active, I() = 200 μ A	1500	3000	5000	
Power-On-Reset Circuit							
901	VCCon	Turn-on Threshold VCC (power-on release)	increasing voltage at VCC		2.6	3.45	V
902	VCCoff	Turn-off Threshold VCC (power-down reset)	decreasing voltage at VCC	1.4	2.4		V
903	VCChys	Threshold Hysteresis	VCChys = VCCon - VCCoff	50	170	300	mV

DIGITAL OUTPUT SIGNALS

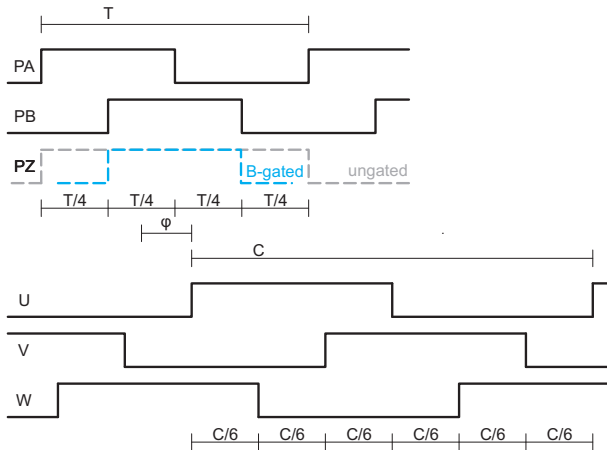

Figure 1: Encoder quadrature and motor commutation signals

iC-PT3325's phased array design determines the optical radius (14.5 mm) and the cycles per revolution for the A and B encoder quadrature signals (2500 CPR native, respectively 5000 CPR interpolated).

The pulse count, period length and phase shift for the U, V, W commutation signals is determined by the code disc.

Sampling is supported by code disc PT5S 33-2500 providing 4 CPR each for U/V/W, with a period length of 90 degrees (C).

A phase shift of 0 degrees (φ) between U and Z edges must be considered during alignment. For detailed specifications, refer to the relevant code disc datasheet, available separately.

ANALOG OUTPUT SIGNALS

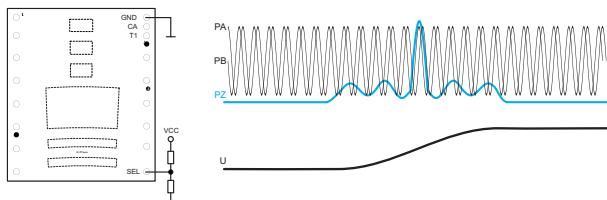

Figure 2: Analog signal output (pin SEL open).

When the operating mode selection input SEL is left open, all digital outputs are disabled and analog output signals are available for test and alignment.

If analog signals are desired permanently, noise immunity can be improved by wiring pin SEL to an external VCC/2 reference.

INDEX GATING oQFN32-5x5-1

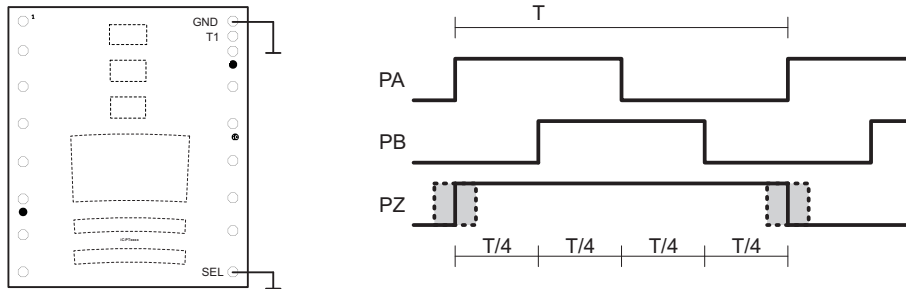

Figure 3: Ungated index signal at x1 interpolation (SEL = low).

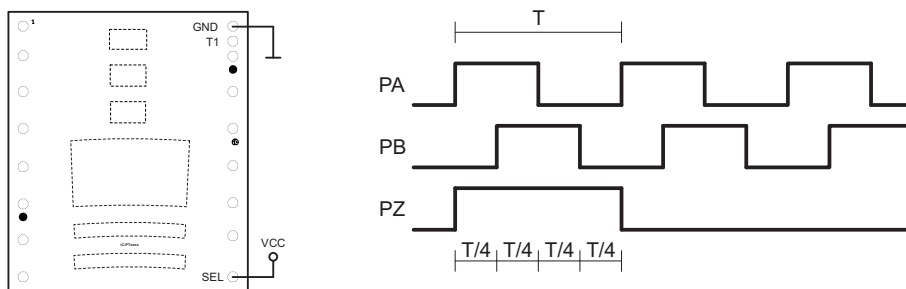

Figure 4: T-gated index signal at x2 interpolation (SEL = high).

INDEX GATING oQFN32-5x5-2

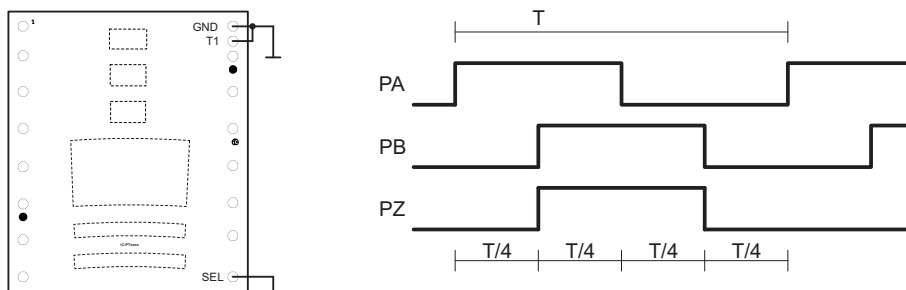

Figure 5: B-gated index signal at x1 interpolation (SEL = low).

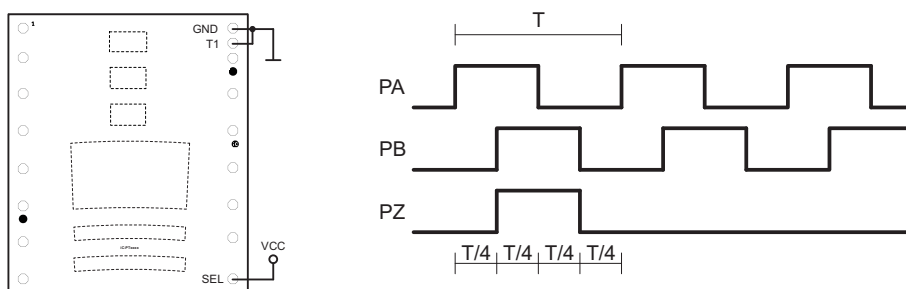

Figure 6: B-gated index signal at x2 interpolation (SEL = high).

iC-PT 3325

6-CH. PHASED ARRAY OPTO ENCODER (33-2500)



Rev C1, Page 10/11

APPLICATION NOTES

Application notes for iC-PTxx series ICs are available separately.

DESIGN REVIEW: Notes on Chip Functions

iC-PT3325		
No.	Function, Parameter/Code	Description and Application Hints
1	Index gating 1/4 T	Index length preset to 1/4 T (AB-gated).

Table 4: Chip release iC-PT3325

iC-PT3325_2		
No.	Function, Parameter/Code	Description and Application Hints
1	Index gating	Package oQFN32-5x5-1: Index length preset to 1 T (ungated/T-gated). Pin 23 is not connected. Package oQFN32-5x5-2: Index length preset to 0.5 T (B-gated). Pin 23 is not connected.

Table 5: Chip release iC-PT3325_2

REVISION HISTORY

Rel.	Rel. Date ¹	Chapter	Modification	Page
C1	2021-08-02	PACKAGING INFORMATION	AOI criteria added with hyperlink to customer information	2
		PACKAGE DIMENSIONS	Update of package drawing and footnote	4
		THERMAL DATA	Item T03: hyperlink to customer information	5
		ELECTRICAL CHARACTERISTICS	Item 302: min. limit adapted	6

iC-Haus expressly reserves the right to change its products, specifications and related supplements (together the Documents). A Datasheet Update Notification (DUN) gives details as to any amendments and additions made to the relevant Documents on our internet website www.ichaus.com/DUN and is automatically generated and shall be sent to registered users by email.

Copying – even as an excerpt – is only permitted with iC-Haus' approval in writing and precise reference to source.

The data and predicted functionality is intended solely for the purpose of product description and shall represent the usual quality and behaviour of the product. In case the Documents contain obvious mistakes e.g. in writing or calculation, iC-Haus reserves the right to correct the Documents and no liability arises insofar that the Documents were from a third party view obviously not reliable. There shall be no claims based on defects as to quality and behaviour in cases of insignificant deviations from the Documents or in case of only minor impairment of usability.

No representations or warranties, either expressed or implied, of merchantability, fitness for a particular purpose or of any other nature are made hereunder with respect to information/specification resp. Documents or the products to which information refers and no guarantee with respect to compliance to the intended use is given. In particular, this also applies to the stated possible applications or areas of applications of the product.

iC-Haus products are not designed for and must not be used in connection with any applications where the failure of such products would reasonably be expected to result in significant personal injury or death (*Safety-Critical Applications*) without iC-Haus' specific written consent. Safety-Critical Applications include, without limitation, life support devices and systems. iC-Haus products are not designed nor intended for use in military or aerospace applications or environments or in automotive applications unless specifically designated for such use by iC-Haus.

iC-Haus conveys no patent, copyright, mask work right or other trade mark right to this product. iC-Haus assumes no liability for any patent and/or other trade mark rights of a third party resulting from processing or handling of the product and/or any other use of the product.

Software and its documentation is provided by iC-Haus GmbH or contributors "AS IS" and is subject to the ZVEI General Conditions for the Supply of Products and Services with iC-Haus amendments and the ZVEI Software clause with iC-Haus amendments (www.ichaus.com/EULA).

¹ Release Date format: YYYY-MM-DD

iC-PT 3325

6-CH. PHASED ARRAY OPTO ENCODER (33-2500)



Rev C1, Page 11/11

ORDERING INFORMATION

Type	Package	Options	Order Designation
iC-PT3325	32-pin optoQFN, 5 mm x 5 mm, thickness 0.9 mm RoHS compliant	Index length preset to 1 T (ungated/T-gated)	iC-PT3325 oQFN32-5x5-1
		Index length preset to 0.5 T (B-gated)	iC-PT3325 oQFN32-5x5-2
Code Disc		2500 PPR +4 PPR, OD/ID \varnothing 33.2/13.0 mm, glass 1 mm	PT5S 33-2500

Please send your purchase orders to our order handling team:

Fax: +49 (0) 61 35 - 92 92 - 692

E-Mail: dispo@ichaus.com

For technical support, information about prices and terms of delivery please contact:

iC-Haus GmbH
Am Kuemmerling 18
D-55294 Bodenheim
GERMANY

Tel.: +49 (0) 61 35 - 92 92 - 0
Fax: +49 (0) 61 35 - 92 92 - 192
Web: <http://www.ichaus.com>
E-Mail: sales@ichaus.com

Appointed local distributors: http://www.ichaus.com/sales_partners