

# GARMIN®

## GPS 19X NMEA 2000®

### INSTALLATION INSTRUCTIONS

#### Important Safety Information

##### CAUTION

To avoid possible personal injury, always wear safety goggles, ear protection, and a dust mask when drilling, cutting, or sanding.

##### NOTICE

When drilling or cutting, always check what is on the opposite side of the surface to avoid damaging the vessel.

For the best performance and to avoid damage to your boat, read all installation instructions before proceeding. Install the device per these instructions. Use the appropriate fasteners, tools, and mounts listed, which are available at most marine dealers.

For more information, go to [support.garmin.com](http://support.garmin.com).

#### Tools Needed

- Drill
- 3.2 mm (1/8 in.) drill bit
- 19 mm (3/4 in.) drill bit for a pole-mount cable-hole
- 25 mm (1 in.) hole saw for a surface-mount cable-hole
- Countersink bit for mounting on fiberglass
- Screws for under-deck mounting
- Screwdriver, appropriate for the screw type
- Marine sealant (optional)
- Additional NMEA 2000 network components as needed



# Mounting the Antenna

## Antenna Mounting Considerations

### ⚠ CAUTION

Do not install or store the antenna near strong magnets, including speakers. A strong magnetic field can damage the antenna.

You can mount the antenna on a flat surface or attach it to a standard 1 in. OD, 14 threads per inch, pipe-threaded pole (not included). You can route the cable outside of the pole or through the pole. For best performance, consider these guidelines when selecting the antenna mounting location.

- To ensure the best reception, the antenna should be mounted in a location that has a clear, unobstructed view of the sky in all directions ①.

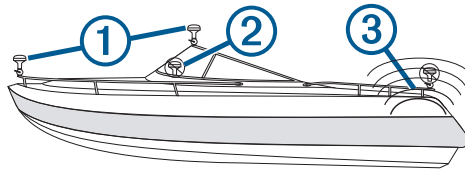

- The antenna should not be mounted where it is shaded by the superstructure of the boat ②, a radome antenna, or the mast.
- The antenna should not be mounted near the engine or other sources of Electromagnetic Interference (EMI) ③.
- The antenna should not be mounted near known ferrous metal objects such as a toolbox or compass.
- If a radar is present, the antenna should be mounted above the path of the radar ④. If necessary, the antenna may be mounted below the path of the radar ⑤.

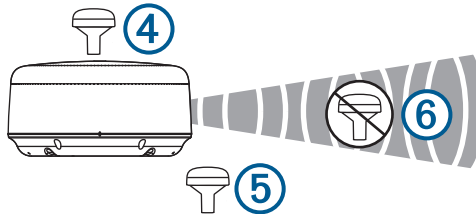

- The antenna should not be mounted directly in the path of the radar ⑥.
- The antenna should not be mounted within 1 m (3 ft.) of a VHF radio antenna or the path of a radar ⑦.

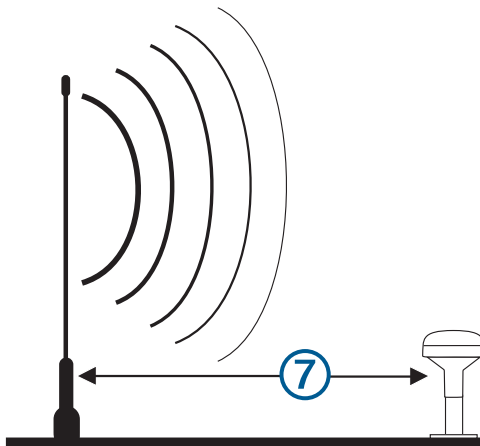

## Testing the Mounting Location

- 1 Temporarily secure the antenna in the preferred mounting location and test it for correct operation.
- 2 If you experience interference with other electronics, move the antenna to a different location, and test it again.
- 3 Repeat steps 1–2 until you observe full or acceptable signal strength.
- 4 Permanently mount the antenna.

## Surface Mounting the Antenna

### NOTICE

If you are mounting the bracket on fiberglass with screws, it is recommended to use a countersink bit to drill a clearance counterbore through only the top gel-coat layer. This will help to avoid cracking in the gel-coat layer when the screws are tightened.

Before you permanently mount the antenna, you must test the mounting location for correct operation ([Testing the Mounting Location](#), page 3).

- 1 Using the surface-mount bracket ① as your mounting template, mark the three pilot-hole locations and trace the cable-hole in the center of the bracket.

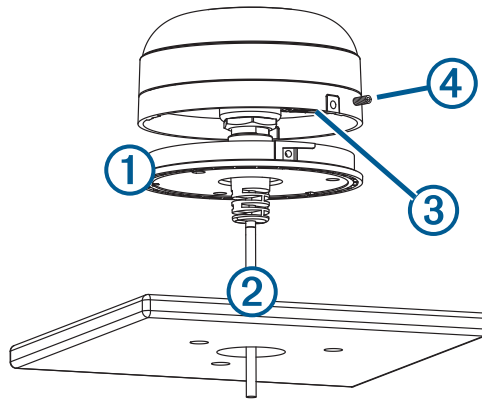

- 2 Set the surface-mount bracket aside.  
Do not drill through the bracket.
- 3 Drill the three 3.2 mm ( $\frac{1}{8}$  in.) pilot holes.
- 4 Drill the 25 mm (1 in.) cable hole in the center.
- 5 Use the included M4 screws to secure the surface-mount bracket to the mounting surface.
- 6 Route the cable ② through the center hole, and connect it to the antenna.
- 7 Verify the large gasket ③ is in place on the bottom of the antenna, place the antenna on the surface-mount bracket, and twist it clockwise to lock it in place.
- 8 Secure the antenna to the mounting bracket with the included M3 screw ④.
- 9 Route the cable away from sources of electronic interference.

## Mounting the Antenna on a Pole

### Mounting the Antenna with the Cable Routed Outside the Pole

Before you permanently mount the antenna, you must test the mounting location for correct operation (*Testing the Mounting Location*, page 3).

- 1 Route the cable through the pole-mount adapter ①, and place the cable in the vertical slot ② along the base of the pole-mount adapter.

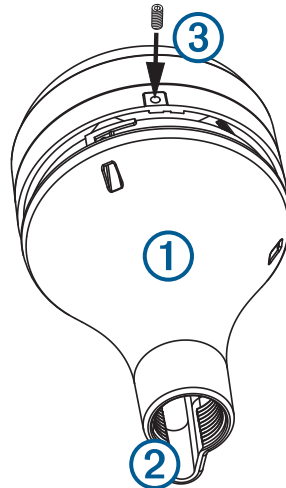

- 2 Screw the pole-mount adapter onto a standard 1 in. OD, 14 threads per inch, pipe-threaded pole (not included).

Do not overtighten the adapter on the pole.

- 3 Connect the cable to the antenna.
- 4 Place the antenna on the pole-mount adapter and twist it clockwise to lock it in place.
- 5 Secure the antenna to the adapter with the included M3 set screw ③.
- 6 With the antenna installed on the pole mount, fill the remaining gap in the vertical cable slot with a marine sealant (optional).
- 7 Attach the pole to the boat if it is not already attached.
- 8 Route the cable away from sources of electronic interference.

## Mounting the Antenna with the Cable Routed Through the Pole

Before you permanently mount the antenna, you must test the mounting location for correct operation (*Testing the Mounting Location*, page 3).

- 1 Position a standard 1 in. OD, 14 threads per inch, pipe-threaded pole (not included) in the selected location, and mark the approximate center of the pole.
- 2 Drill a hole using a 19 mm ( $\frac{3}{4}$  in.) drill bit for the cable to pass through.
- 3 Fasten the pole to the boat.
- 4 Thread the pole-mount adapter onto the pole.  
Do not overtighten the adapter.
- 5 Route the cable through the pole and connect it to the antenna.
- 6 Place the antenna on the pole-mount adapter and twist it clockwise to lock it in place.
- 7 Secure the antenna to the adapter with the included M3 set screw ①.

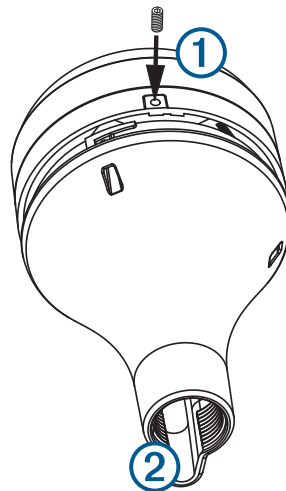

- 8 With the antenna installed on the pole mount, fill the vertical cable slot ② with a marine sealant (optional).
- 9 Route the cable away from sources of electronic interference.

## Mounting the Antenna Under a Surface

### NOTICE

Verify that the supplied screws will not penetrate the surface before you install the under-deck mounting bracket. If the supplied screws are too long, use surface-appropriate screws instead.

Because the antenna cannot acquire signals through metal, it must be mounted under a fiberglass surface only.

- 1 Determine and test the location under a fiberglass surface where you want to mount the antenna (*Testing the Mounting Location*, page 3).

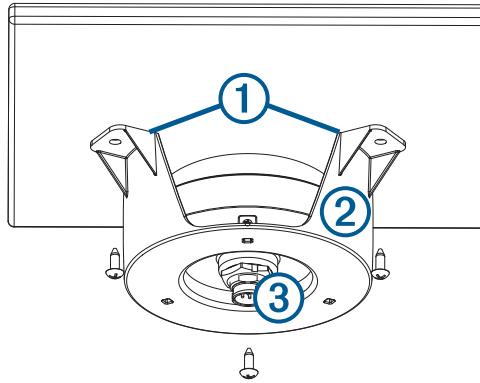

- 2 Place the adhesive pads ① on the under-deck mounting bracket ②.
- 3 Place the antenna in the under-deck mounting bracket.
- 4 Adhere the under-deck mounting bracket to the mounting surface.
- 5 Secure the under-deck mounting bracket to the mounting surface with screws.
- 6 Connect the cable to the antenna ③.
- 7 Route the cable away from sources of electronic interference.

## Connecting the Antenna

### NMEA 2000 Network Connection

If you do not have an existing NMEA 2000 network, you must install a NMEA 2000 network on your boat. For more information on NMEA 2000, go to [garmin.com/manuals/nmea\\_2000](http://garmin.com/manuals/nmea_2000).

The antenna is packaged with a NMEA 2000 T-connector and a NMEA 2000 drop cable. You will use these two components to connect the antenna to your existing NMEA 2000 network.

A 6 m (20 ft.) drop cable is included. If more cable is needed, add an extension to your NMEA 2000 backbone, based on the NMEA 2000 guidelines. A shorter drop cable can be installed if desired.

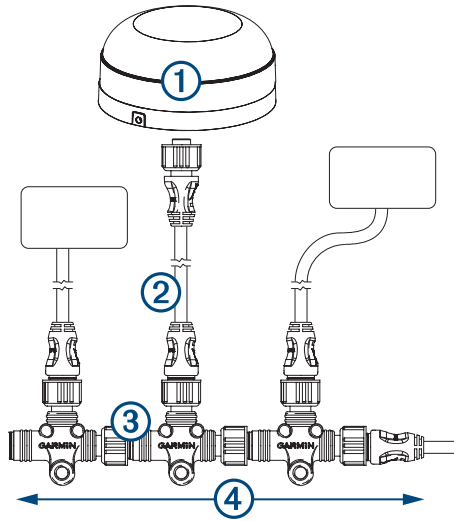

①	GPS 19x antenna
②	NMEA 2000 drop cable
③	NMEA 2000 T-connector
④	NMEA 2000 backbone

### Antenna Configuration

To access the NMEA 2000 configuration menu on your Garmin® device, consult the documentation provided with your device. While viewing the NMEA 2000 configuration menu on your Garmin device, you must select the antenna, then select **Review** to change these settings.

**WAAS/EGNOS:** Enables WAAS (Wide Area Augmentation System in North America) and EGNOS (European Geostationary Navigation Overlay Service) to provide more accurate position information.

**Speed Filter:** Enables data averaging to provide smoother position updates, reducing unnecessary drift-alarm triggers. You can enable it when stationary or for lower speeds when it is most helpful, or disable it for higher speeds.

**Auto Locate:** Allows you to clear cached satellite data, forcing the device to acquire new data. This can be helpful if you have moved the boat many miles without using the antenna.

**GLONASS:** Enables GLONASS (Global Navigation Satellite System in Russia) satellites.

**Factory Defaults:** Allows you to reset the antenna to factory default. You will lose all custom configuration settings.

## Cleaning the Outer Casing

### NOTICE

Avoid chemical cleaners and solvents that can damage plastic components.

- 1 Clean the outer casing of the device using a cloth dampened with a mild detergent solution.
- 2 Wipe the device dry.

## Appendix

### Software Update

You must update the Garmin chartplotter software when you install this device. For instructions on updating the software, see your chartplotter owner's manual at [support.garmin.com](http://support.garmin.com).

### Specifications

Dimensions (diameter x height)	91.6 × 49.5 mm ( 3 <sup>19</sup> / <sub>32</sub> × 1 <sup>15</sup> / <sub>16</sub> in.)
Weight	201 g (7.1 oz.)
NMEA 2000 drop cable length	6 m (19 ft., 8 in.)
Temperature range	From -30° to 80°C (from -22° to 176°F)
Case material	Fully gasketed, high-impact plastic alloy
Water rating	IEC 60529 IPX7 <sup>1</sup>
Compass-safe distance	150 mm (5.9 in.)
Power input source	9 to 16 Vdc, unregulated
Input current	40 mA @ 12 Vdc
NMEA 2000 LEN @ 9 Vdc	2 (100 mA)
NMEA 2000 draw	40 mA @ 12 Vdc

<sup>1</sup> The device withstands incidental exposure to water of up to 1 m for up to 30 min. For more information, go to [www.garmin.com/waterrating](http://www.garmin.com/waterrating).



## NMEA 2000 PGN Information

### Transmit

059392	ISO acknowledgment
060928	ISO address claimed
126208	Request group function
126464	Transmit and receive PGN list group function
126992	System time
126996	Product information
129025	Position: Rapid update
129026	COG and SOG: Rapid update
129029	GNSS position data
129539	GNSS DOPs
129540	GNSS Sats in view

### Receive

059392	ISO acknowledgment
059904	ISO request
060928	ISO address claimed
126208	Request group function

## Battery Notice

### NOTICE

Contact your local waste disposal department to dispose of the device/batteries in accordance with applicable local laws and regulations.

## Declaration of Conformity

Hereby, Garmin declares that this product is in compliance with the Directive 2014/53/EU. The full text of the EU declaration of conformity is available at the following internet address: [garmin.com/compliance](http://garmin.com/compliance).

## UK Declaration of Conformity

Hereby, Garmin declares that this product is in compliance with the relevant statutory requirements. The full text of the declaration of conformity is available at the following internet address: [garmin.com/compliance](http://garmin.com/compliance).

## Innovation, Science and Economic Development Canada Compliance

This device contains licence-exempt transmitter(s)/receiver(s) that comply with Innovation, Science and Economic Development Canada's licence-exempt RSS(s). Operation is subject to the following two conditions: (1) this device may not cause interference, and (2) this device must accept any interference, including interference that may cause undesired operation of the device.

## FCC Compliance

This device complies with part 15 of the FCC Rules. Operation is subject to the following two conditions: (1) this device may not cause harmful interference, and (2) this device must accept any interference received, including interference that may cause undesired operation.

This equipment has been tested and found to comply with the limits for a Class B digital device, pursuant to part 15 of the FCC rules. These limits are designed to provide reasonable protection against harmful interference in a residential installation. This equipment generates, uses, and can radiate radio frequency energy and may cause harmful interference to radio communications if not installed and used in accordance with the instructions. However, there is no guarantee that interference will not occur in a particular installation. If this equipment does cause harmful interference to radio or television reception, which can be determined by turning the equipment off and on, the user is encouraged to try to correct the interference by one of the following measures:

- Reorient or relocate the receiving antenna.
- Increase the separation between the equipment and the receiver.
- Connect the equipment into an outlet on a circuit different from that to which the receiver is connected.
- Consult the dealer or an experienced radio/TV technician for help.

This product does not contain any user-serviceable parts. Repairs should only be made by an authorized Garmin service center. Unauthorized repairs or modifications could result in permanent damage to the equipment, and void your warranty and your authority to operate this device under Part 15 regulations.

## Limited Warranty

The Garmin standard limited warranty applies to this accessory. For more information, go to [www.garmin.com/support/warranty](http://www.garmin.com/support/warranty).

© 2012 Garmin Ltd. or its subsidiaries

Garmin® and the Garmin logo are trademarks of Garmin Ltd. or its subsidiaries, registered in the USA and other countries. These trademarks may not be used without the express permission of Garmin.

NMEA 2000® and the NMEA 2000 logo are registered trademarks of the National Marine Electronics Association.

Garmin Corporation